

## WHAT CAUSES HOT OIL AND WHY IS IT A CONCERN?

Hot oil is caused by the friction of pushing oil through a hydraulic system. The motion of the oil creates friction which, in turn, produces heat. (Surprisingly, the size or horsepower of the pump's motor is not a major contributor to oil heating.)

During operation, oil is pumped through hydraulic components such as jacks, control valves and rupture valves. Even the elbows and the oil lines themselves contribute to oil heating. Remote machine rooms add more distance and bends in the line and therefore add more friction.

The elevator is a factor as well - the more often an elevator runs and the more weight it carries, the hotter the oil gets. If the rails are poorly installed and the car does not ride smoothly in the shaft, that produces friction which in turn produces heat.

Holeless applications generally run hotter than borehole applications, because the jack or jacks do not get the benefit of being buried in the ground which is a natural coolant (average underground temperatures are typically 50° - 55° F in temperate North America).

## HOW DOES HOT OIL EFFECT A HYDRAULIC SYSTEM?

When the oil in your hydraulic system becomes too hot, its viscosity decreases. Elevator performance degrades - the valves act erratically and produce an irregular ride. Thermal cutouts can cause shut-downs. Furthermore, high oil temperatures cause seals and other elevator components to deteriorate prematurely, leading to more repairs and frequent downtime.

## WHAT REAL-LIFE CONDITIONS TYPICALLY PRODUCE HOT OIL?

It's not easy to predict during the design stage if an installation is prone to a hot oil condition. However, there are some indicators that show possible problems.

Elevator design is a prime issue. Twin jack holeless elevators with 2 or 3-stage telescopic jacks are prone to generate a hot oil condition.

Installation quality can cause oil heating. For instance, the adjustment of the control valve (i.e. time/distance of leveling speed) can contribute to the flow of the oil and its heating. Rails that are not installed plumb may cause binding during travel and produce additional friction. Multiple 90° elbows in the line will produce more stress and heat.

Usage is another determiner. The more the car is used fully loaded, the more friction is generated. The more slow downs/stops it makes, the more friction is produced through the control valve.

## HOW DOES AN OIL COOLER WORK? WHAT ARE THE BENEFITS?

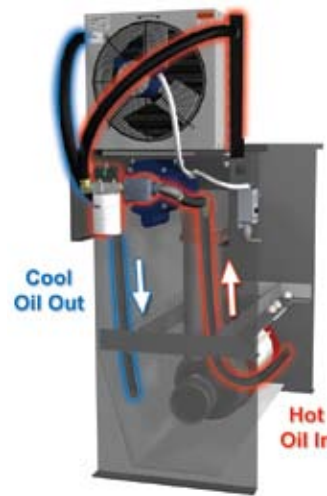

A quality oil cooler (such as the MEI 10248 shown on the back) addresses hot oil problems by continuously monitoring the oil temperature. When the oil temperature in the reservoir reaches a preset limit, the oil cooler begins to circulate oil from the reservoir through its radiator. This reduces oil temperature by as much as 40° F depending on site conditions.

Because the oil cooler operates independently of your elevator system, the oil can be circulating and cooling when the car is not moving. This keeps the oil at a lower average temperature. The resulting improvement in elevator performance, reliability, and component life can have a significant effect on elevator traffic handling and customer satisfaction.

As an added feature, a good oil cooler also filters the oil as it flows, resulting in longer life for hydraulic system components.

## IS AN OIL COOLER NEEDED FOR YOUR INSTALLATION?

If the answer is YES to three or more of the questions below, the hydraulic system on your elevator may need an oil cooler.

Does the oil temperature for your elevator average over 115° F?

Does the elevator have more than 50 starts per hour for 6 hours out of 24?

Does the elevator carry 50% or more of the rated load 40 times per hour for more than 1 hour out of 24?

Is the elevator a holeless elevator (in other words - is the elevator's hydraulic jack sitting entirely in the hoistway)?

Does the elevator total travel exceed 25 feet?

# Hydraulic Accessories by MEI

## Oil cooler and silencers

**Oil cooler** by Minnesota Elevator components CSA certified

Part Number	Description
MEI-10248	Oil cooler, with filter

The **MEI Oil Cooler** reduces the oil temperature by nearly 40° F, (depending on site conditions). The cooler also filters the oil which results in smoother stops and starts, improved levelling and extended component life. The oil cooler can be mounted directly or remotely. **NOTE:** Remote installations should not exceed 110 ft horizontal or 55 ft vertical from tank.

### BENEFITS

- smoother stops and starts and improved leveling
- extended component life when oil is cooled and filtered
- fewer nuisance shutdowns
- reduces "hot" oil odor

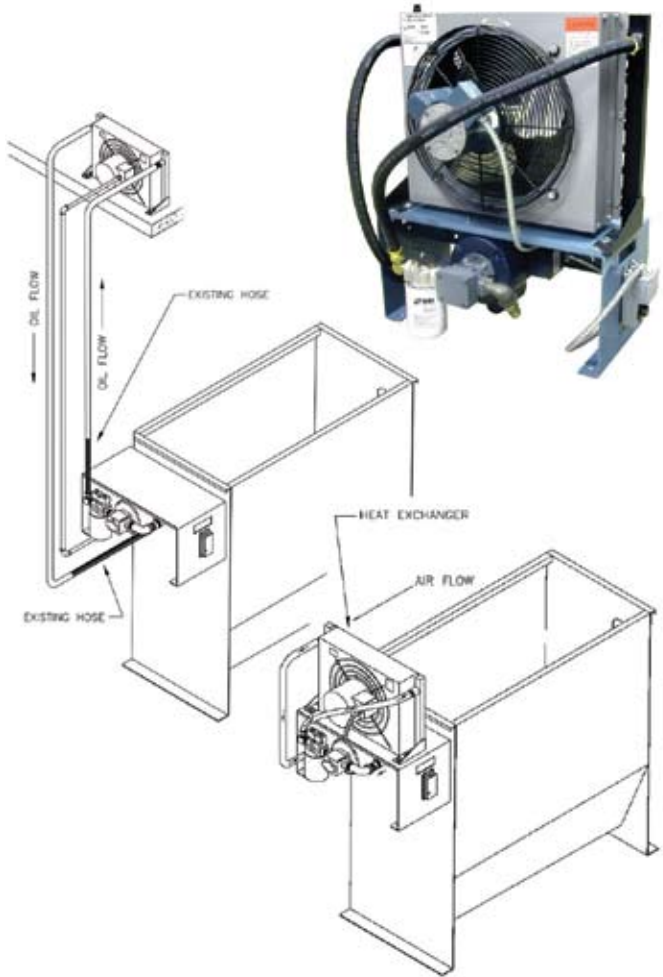

## Silencer by Minnesota Elevator

Part Number	Description
MEI-19317	Silencer, 220 max. GPM, fits 2 x 2 in. grooved coupling, 13-1/4 L x 4-5/8 in. O.D., 28 lbs., rated to 1000 PSI
MEI-19319	Silencer, 360 max. GPM, fits 2-1/2 x 3 in. grooved coupling, 13-1/4 L x 4-5/8 in. O.D., 28 lbs., rated to 1000 PSI

The **MEI Silencer** uses a bladder system with air pressure to reduce excessive noise that may be generated by a hydraulic system.



Call Draka Elevator Products customer service or email us at [drakaep-info@draka.com](mailto:drakaep-info@draka.com) with any questions you may have involving hydraulics.



# Draka

Industry & Specialty | Elevator Products

1-877-DRAKA-EP • [www.draka-ep.com](http://www.draka-ep.com) • 1-877-408-HELP

**All the Products. All the Service. All the World.**

Draka Elevator Products, Inc.

2151 N. Church St. • Rocky Mount, NC 27804

1-252-972-6000 • 1-877-DRAKA EP (372-5237) • 1-252-972-6001 fax

Draka Elevator Products and the Draka Globe Design are trademarks of Draka Elevator Products, Inc.

© 2008 Draka Elevator Products, Inc. All Rights Reserved.