

IMPORTANT! FOLLOWING THESE PROCEDURES WILL ENSURE PROPER TRAVELING CHARACTERISTICS AND OPERATION OF THE CABLE. ONLY FULL COMPLIANCE WITH THESE PROCEDURES WILL ENSURE FULL PRODUCT WARRANTY COVERAGE. THIS IS ONLY A BRIEF SUMMARY OF PROCEDURES; FOR MORE DETAILS, REFER TO THE DRAKA ELEVATOR PRODUCTS, INC. SUPER-FLEX TRAVELING CABLE INSTALLATION GUIDE.

1) STORAGE AND HANDLING

The cables should be inspected immediately when they arrive at the job site to ensure they have not been damaged in route. Store traveling cables in a secure area to avoid damage resulting from other construction activities.

2) CABLE END PREPARATION

Take extreme care when removing the jacket and braid to avoid damaging the insulation of the wires. If available, use an FCJ Stripper (part # 36-135 -M1) or Flexi-Peeler (part # 36-060) to remove the jacket. Remove the braid with the Sock Slicer (part # 36-177). Other methods include using medical scissors or making short, light strokes with a utility knife.

Use stripper/peeler to cut jacket, then braid cutter

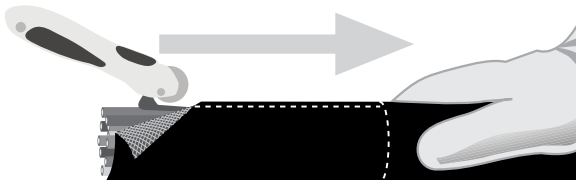

3) RAISING CABLE IN HOISTWAY

When pulling cable up a hoistway or lowering it by use of the car, the cable should pay off from the bottom of the reel or coil. A properly-sized split wire mesh grip can be used to raise the cable.

If fed down the hoistway, it should pay off from the top of the reel or coil to minimize bending.

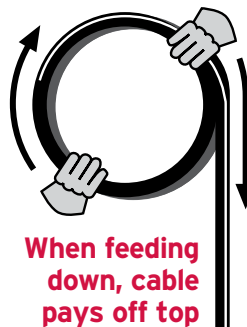
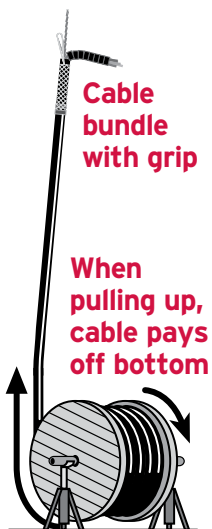

4) PRE-HANGING THE CABLE

Pre-hanging the cable relieves internal stress that may have developed during re-reeling and handling. This procedure is used to secure the steel support and outer cable core as a unit while the lower cable end hangs freely.

It is recommended that the cable should remain in the pre-hanging position for at least 24 hours

It is recommended to temporarily secure the cable and prevent the upper cable end from rotating during pre-hanging

The lower end of the cable should clear the pit floor by 1 foot • 30 cm to allow space for any straightening of the cable

The cable should be pulled away and prevented from resting against the wall or any other part of the hoistway

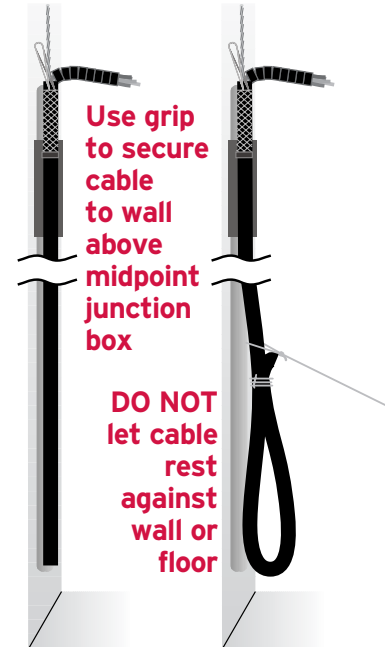

4A) ALTERNATE PRE-HANGING METHOD

This alternate method for pre-hanging is explained in the Super-Flex Installation Guide. Although this method provides some degree of torsional relief, IT DOES NOT ASSURE COMPLETE TORSIONAL STRESS-RELIEF because the lower cable end is not free to rotate.

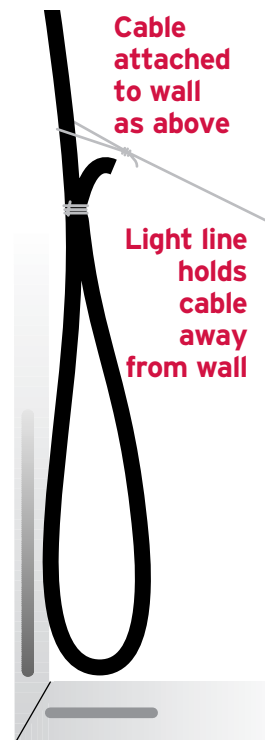

5) ATTACHMENT TO HANGERS

The steel support member must be permanently attached prior to connecting any electrical conductors. Sufficient slack should be provided in the conductors to prevent the weight of the cable from being applied to them. While several methods exist to support traveling cables, the Draka EP Universal Hanger is recommended for steel supported cables. See Table 1 for part numbers.

Table 1: Universal Hanger Part Numbers

Part Number	Steel Core Dia. inches • mm	No. of Cables Held	Max. per Cable Load lbs • kg
3/32-1 SBKT	3/32 • 2.4	1 cable	500 • 227
5/32-1 SBKT-R	5/32 • 4.0	1 cable	700 • 318
5/32-2 SBKT-R	5/32 • 4.0	2 cables	700 • 318
1/4-1 SBKT	1/4 • 6.4	1 cable	1250 • 568
1/4-2 SBKT	1/4 • 6.4	2 cables	1250 • 568
1/8-1 SBKT	1/8 • 3.2	1 cable	500 • 227

Strip 8 inches • 20 cm of insulation from the steel support member (15 inches • 40 cm if adding cable stop hardware). Insert the bare steel into the bottom end of the hanger strand vise until the steel protrudes from the top end. Pull down on the steel to lock it into position.

Form the cable stop by passing the flat washer over the steel so that it rests on the strand vise. Form a loop with the steel around the thimble and fasten the clip. There should be at least 1/2 inch • 13 mm clearance between the washer and the clip.

Immediately after the steel support member is terminated, tighten the metal straps to secure the traveling cable. This will allow the cable to act as a single unit; the rotation position of the cable is set and secured by tightening these straps

Wire mesh grips are recommended for supporting the cable lengths of 200 feet • 61 m or less (as specified in the National Electrical Code); electrical tape must be wrapped on the bottom base of the mesh grip to prevent it from slipping

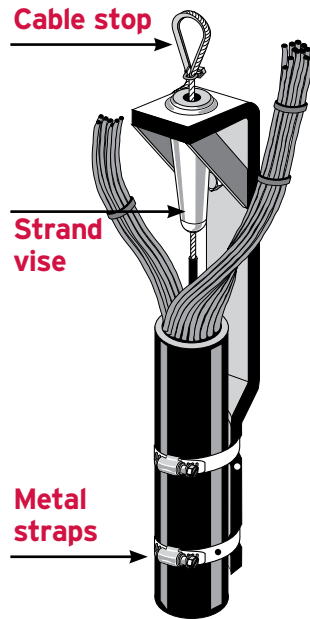

NOTE: The manufacturer's identification markings on the cable's jacket should not be used to determine the alignment of the cable.

6) FINAL INSTALLATION STEPS

For optimum performance, sides of the cable loop should remain parallel during the elevator operation. Loop curvature should be smooth and free of kinks and pivot points. Loop diameters are determined by the formula Cable OD x 30. The loop diameter should be ±10% of this calculation.

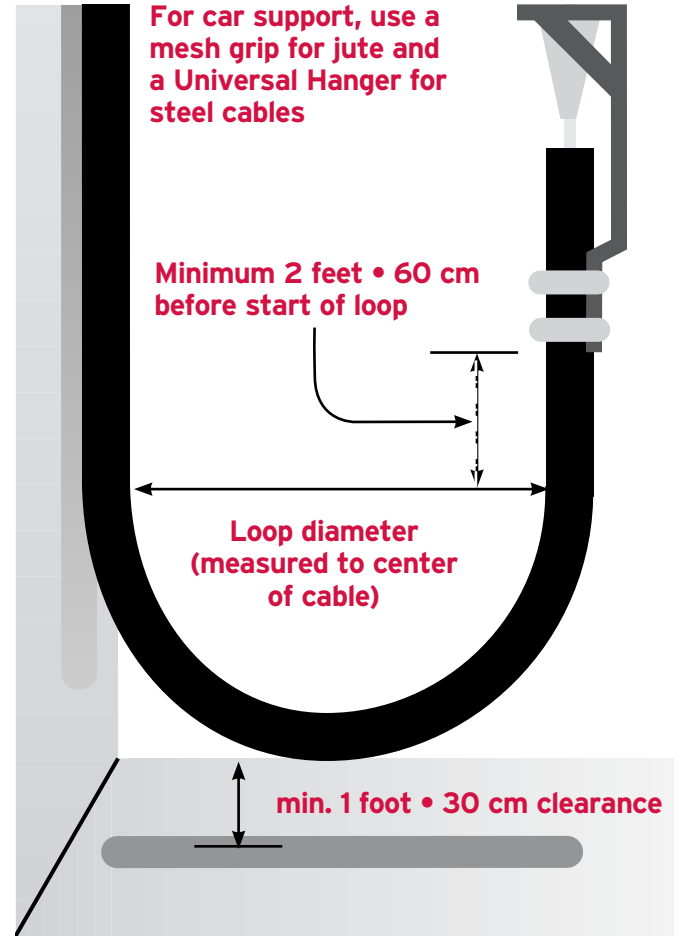

Finally, a routine inspection program should be implemented to maximize product performance and safety.

NOTE: All installation hardware can be obtained from Draka EP. Consult our catalog or call us for sizing information.

Call Draka Elevator Products customer service or email us at drakaep-info@draka.com with any questions you may have involving traveling cable



Draka

Industry & Specialty | Elevator Products

1-877-DRAKA-EP • www.draka-ep.com • 1-877-408-HELP

All the Products. All the Service. All the World.

Draka Elevator Products, Inc.
 2151 N. Church St. • Rocky Mount, NC 27804
 1-252-972-6000 • 1-877-DRAKA EP (372-5237) • 1-252-972-6001 fax
 Draka Elevator Products and the Draka Globe Design are trademarks of Draka Elevator Products, Inc.
 © 2008 Draka Elevator Products, Inc. All Rights Reserved.